

They are rotary vane vacuum pumps, lubricated with oil recirculation, with a suction flow rate of 5 m³/h.

Characterized by a simple construction, they are robust, compact, and well-cooled.

The lubrication is adjustable by using a drop oiler located at the intake.

To minimize the overall dimensions, the pump's rotor is assembled to the motor shaft.

The BVS and BVL series pumps are supplied with single-phase or three-phase electric motors.

The motor and pump are cooled by the motor fan.

On the pump discharge, there is an oil recovery tank containing a separator filter that prevents the formation of oil mists and reduces noise.



Use and installation

The use of these pumps is essential when the fluid to be aspirated contains solvent vapors, water condensates, or any other substances that could contaminate the lubricating oil.

For the installation of OMMER vacuum pumps, it is sufficient to connect them to the vacuum circuit and set up the electrical connection to the motor.

Please ensure the correct rotation direction of the pump.

005L			
Frequency		50Hz	60Hz
Flow rate	m ³ /h	5	6
Ultimate pressure	mbar	75	
Motor performance	3~	230/400±5%	265/460±5%
Volt	1~	230±5%	
Motor power	3~	0,25	0,30
kW	1~	0,25	
Motor protection	IP	55	
Rotation speed	rpm	1400	1700
Motor shape		Custom	
Motor size		71	
Weight	kg	12	

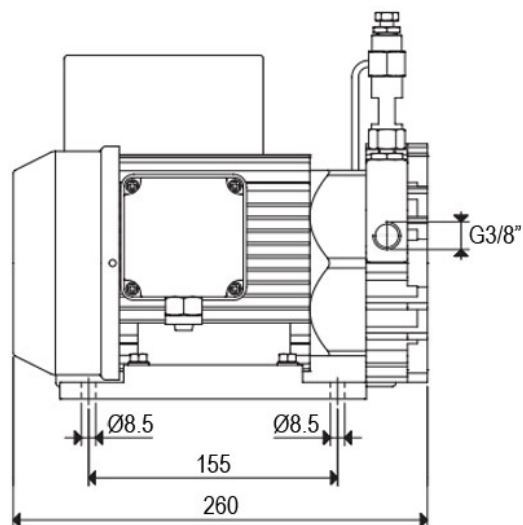
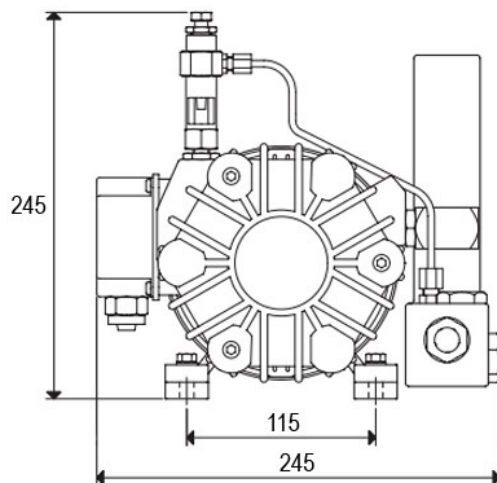

Data and dimensions are not mandatory. O.M.M.E.R. S.r.l. reserves the right to make changes and improvements at any time and without notice.

